



**enertexbayern** gmbh  
simulation entwicklung consulting

## Manual and configuration

# Enertex® KNX HV Dimmer



## Note

The contents of this document may not be reproduced, transmitted, distributed or stored in any form, in whole or in part, without the prior written permission of Enerterx® Bayern GmbH.

Enerterx® is a registered trademark of Enerterx® Bayern GmbH. Other product and company names mentioned in this manual may be trademarks or trade names of their respective owners.

This manual is subject to change without notice or announcement and makes no claim to completeness or correctness.

## Content

<b>Notes</b> .....	<b>3</b>
<i>Safety Notes</i> .....	3
<i>Intended Use</i> .....	3
<i>Parameter Description in ETS</i> .....	3
<i>Short Description</i> .....	3
Functional overview.....	4
<b>Usage of the Device</b> .....	<b>5</b>
<i>Mounting and Connection</i> .....	5
Nominal load per channel.....	6
Parallel Connection of Channels.....	6
Power Supply.....	6
Calibration of the Luminaires.....	6
<i>Commissioning without ETS</i> .....	8
Menu Structure on the Device Display.....	8
Alarm functions.....	9
Manual mode (Set Brightness).....	9
Calibrate the light source manually (commissioning).....	10
Manual test.....	10
<i>Commissioning with ETS</i> .....	12
Dimming Curves.....	12
Light Sources.....	13
Load Type.....	13
Control Curve.....	13
Start Learning the Control Curve.....	14
Default Control Curve for the Lamp.....	14
Adjustment of Min./Max. Control Values.....	14
Interactive fine tuning.....	15
Configuration Guidelines for Pleasant Dimming Behavior.....	15
Switch-On Threshold Issue with Certain LED Lamps.....	16
Status of Standardization: Operating Mode LED Combination Leading-/Trailing-Edge... 16	
<i>Factory reset</i> .....	16
<b>Device description</b> .....	<b>17</b>
<i>Display and control elements</i> .....	17
<i>Measurements and Counters</i> .....	17
Measurements.....	17
Metering.....	17
<i>Luminaire protection</i> .....	17
Explanations on the I <sup>2</sup> t shutdown.....	18
<b>ETS Application</b> .....	<b>19</b>
<i>Specification</i> .....	19
<i>Database file</i> .....	19
<i>Parameters</i> .....	19
<i>Communication objects</i> .....	19
<b>Device Specifications</b> .....	<b>25</b>

## Notes

### Safety Notes

- Installation and assembly of electrical devices may only be carried out by qualified electricians.
- When connecting KNX interfaces, professional knowledge acquired through KNX training is assumed.
- Failure to follow the instructions may result in damage to the device, a fire, a dangerous electric shock, or other hazards.
- This manual is an integral part of the product and must remain with the end user.
- The manufacturer is not liable for costs or damages incurred by the user or third parties through the use of this device, misuse, or disturbances in the connection, disturbances of the device, or the associated devices.
- Opening the housing or making other unauthorized modifications and/or conversions to the device will void the warranty!
- The manufacturer is not liable for improper use.

### Intended Use

- Switching and dimming of incandescent lamps, dimmable LED luminaires, HV halogen lamps, and NV halogen lamps with conventional transformers or dimmable electronic transformers.
- Installation in distribution boards on a DIN EN 6071 mounting rail.5

### Parameter Description in ETS

The documentation of the application parameters is largely integrated directly into ETS. To display explanations and help texts, select the HV Dimmer application in ETS and activate the Context Help button in the context menu bar.

### Short Description

The Enertex® KNX HV Dimmer is a universal dimming actuator for all dimmable 230 VAC luminaires. The dimmer is available as a 4-channel and as an 8-channel variant. The 8-channel variant has an installation width of 6 module widths (MW). The smaller 4-channel variant requires an installation width of 4 MW.

The dimmer employs two innovative techniques to ensure continuously variable, flicker-free, and harmonious dimming across the entire dimming range: Lamp correction method (LKV) and low-light stabilization method (SSV). Additionally, selectable dimming curves provide the freedom to configure the desired dimming behavior.

The Lamp correction method (LKV) detects and corrects even the slightest irregularities in the luminaires to guarantee smooth and harmonious dimming transitions. The low-light stabilization method (SSV) ensures extremely precise and stabilized control of the luminaire, perfectly synchronized with the grid frequency. The result is a stable, flicker-free light even at very low brightness levels, where the human eye is particularly sensitive to brightness fluctuations.

The Enertex® KNX HV Dimmer significantly mitigates the problem of residual currents. Residual currents are the cause of the constant visible glow of LED luminaires (often of low power) when controlled by conventional dimmers. However, the high-quality control of the Enertex Dimmer considerably reduces these residual currents so that the lamps remain completely dark when switched off.

With the help of the display and control buttons, the dimmer—including its wiring and luminaires—can also be tested without a PC and ETS software. An additional convenience for the installer is provided by the automated commissioning process at the push of a button, which automatically determines the optimal dimming parameters for the luminaires of a channel.

Subsequent fine-tuning of the parameters—either directly on the device or via ETS—allows the Low-Light Stabilization Procedure and the Light Source Correction Procedure to exhibit the full range of the dimmer's excellent dimming properties.

To record the energy costs of the lighting, the device provides an energy and cost meter for each channel via communication objects.

Furthermore, the device offers a very extensive ETS application, including: time-controlled dimming, sleep and wake-up light, staircase lighting function with shutdown warning, timers, scenes, bit scenes, lock functions, and comprehensive logic functions.

Bus communication can optionally be encrypted using KNX Data Secure.

## Functional overview

- 8 or 4 dimming channels, 230 VAC, up to 250 W per channel
- DIN rail mounting device with a compact 6 MW (8-channel variant) or 4 MW (4-channel variant) installation width
- For LED luminaires, HV halogen lamps, and NV halogen lamps with transformer/EVG
- Support for both leading-edge and trailing-edge control
- Optimal dimming performance over the widest possible dimming range—even with challenging LED luminaires—by utilizing innovative dimming methods: Light Source Correction Procedure and Low-Light Stabilization Procedure
- Smooth and harmonious dimming transitions thanks to the adaptive Lamp Correction Method (LKV) and additionally selectable dimming curves
- Low-Light low-light Stabilization Method (SSV) for a stable, flicker-free light at very low brightness levels
- Minimal losses per channel: Standby < 0.2 W, full load < 2 W
- Each channel features an energy and cost meter with precise active power measurement in accordance with accuracy class A (2%)
- Helpful commissioning and diagnostic functions via the display and buttons on the device
- Automated commissioning with load detection and luminaire calibration, as well as a final self-diagnosis of the luminaire's dimming capability
- Overload, overvoltage, short-circuit, and temperature protection with alarm notification
- Configurable luminaire protection
- Parallel operation of up to 4 channels with a total output of 1000 W
- Extensive application features: time-controlled dimming, sleep and wake-up light, staircase lighting function with shutdown warning, timers, scenes, bit scenes, lock functions, and comprehensive logic functions

## Usage of the Device

### Mounting and Connection

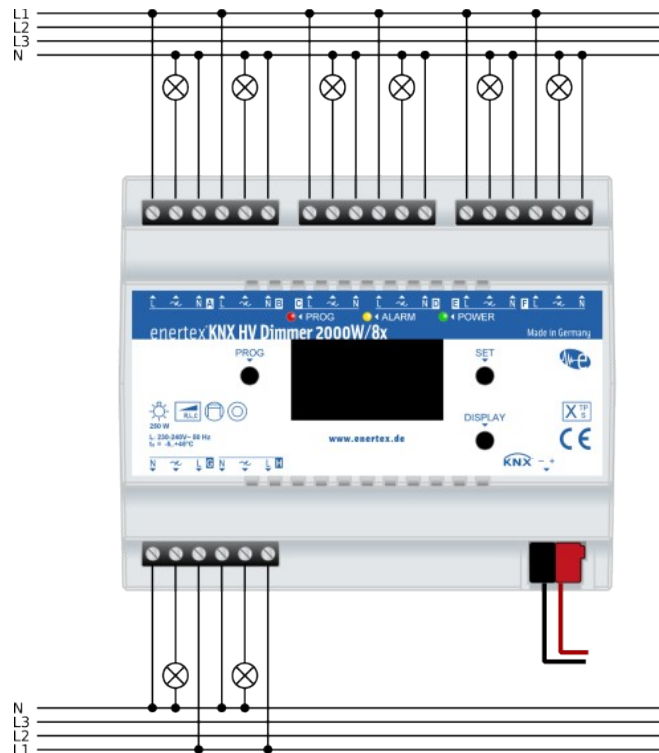

Figure 1: Connection diagram with example wiring for 8-channel variant

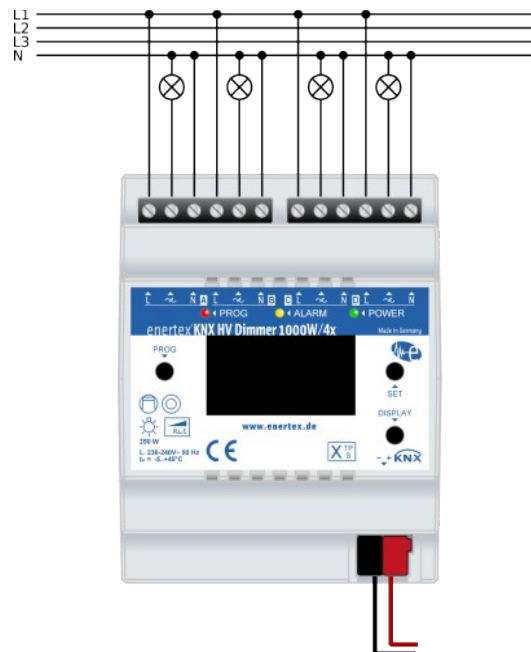

Figure 2: Connection diagram with example wiring for 8-channel variant

#### Risk of fatal electric shock!

Before working on the device, de-energize it and cover any live parts in the surrounding area! Mount the device in the distribution board on a DIN rail. Connect the luminaires according to Connection diagram 1 or 2, respectively.

Note that the connection diagram is only exemplary and may vary in individual cases. The maximum load per channel must be selected according to Table 1 For higher loads, channels can be

operated in parallel. Please observe the instructions in the section "Parallel Connection of Channels."

The channels are built internally isolated from each other. Therefore, every N or L conductor must always be connected, even if the channels are connected in parallel. Each channel can thus also be assigned its own RCD circuit.

The phase conductors L1, L2, and L3 can be freely assigned to the individual channels.

## Nominal load per channel

Depending on the type of load, the following loads can be connected per channel:

Load type	Max. Load	Recommended setting for ETS parameter Load type
HV halogen lamps	250 W	• Measured load type (leading/trailing edge phase control)
Incandescent lamps	250 W	• Measured load type (leading/trailing edge phase control)
HV LED lamps in trailing edge phase control	200 W <sup>2</sup>	• Measured load type (leading/trailing edge phase control)
HV LED lamps <sup>1</sup> in leading edge phase control	100 W <sup>1,3</sup>	• LED (leading edge) <sup>1</sup>
Electronic transformer in trailing edge phase control	200 W <sup>2</sup>	• Measured load type (leading/trailing edge phase control)
Wound transformers in leading edge phase control HV-Halogenlampen	200 W	• Measured load type (leading/trailing edge phase control) <sup>1</sup>

Table 1: Max. Loads for one channel

<sup>1</sup> For old LED lamps that explicitly only allow the leading edge phase control method according to the operating instructions, the load type parameter must be permanently set to LED leading edge phase control. Automatic detection of the load type during the calibration process is not possible.

<sup>2</sup> The upper limit of 200W for electronic loads in phase cut-off mode is defined in accordance with EN IEC 61000-3-2 for limiting harmonic currents in the low voltage range. nnungsnetz festgelegt und ist keine technische Vorgabe der Dimmelektronik (z.B. aufgrund von Stromhöhen oder Wärmeentwicklung).

<sup>3</sup> The upper limit of 10W for electronic loads in the phase angle control method is defined in accordance with EN IEC 61000-3-2 for limiting harmonic currents in the low-voltage network.

## Parallel Connection of Channels

Up to four channels may be connected in parallel. This allows summed loads of up to 1000 W to be dimmed. In parallel operation, the maximum power ratings from section 1 are multiplied by the number of parallel channels. When using parallel channels, the corresponding mode must be selected in ETS. The combination of parallel channels is not arbitrary and must be connected according to the specifications provided in ETS.

**Caution: Damage to the device may occur if the connection and the ETS parameterization in the "Operating Mode" parameter are inconsistent when using parallel channels.**

Additionally, parallel-connected channels must be supplied from the same phase; otherwise, a short circuit between the phases will occur.

## Power Supply

The Enertex® KNX HV Dimmer is powered exclusively via the KNX Bus. Therefore, ETS parameterization can be performed even if no 230 V mains voltage is present at the device.

## Calibration of the Luminaires

Two methods for optimized control of the luminaires are implemented in the device:

1. Smooth and harmonious dimming transitions thanks to the Lamp Correction Method (LKV)
2. Low-Light Stabilization Method (SSV) for stable, flicker-free light at very low brightness levels

Both methods require a calibration process of the luminaire, which is also necessary when the luminaire is replaced. This process can be initiated at any time by the end user by pressing the

display button (approximately 10 seconds). As a result, all 8 channels (or 4 channels) are always calibrated simultaneously. Further details on this calibration process can be found in the following chapters.

## Commissioning without ETS

After connecting the channels to the device according to the wiring diagram, the lamps can be commissioned with or without ETS. For commissioning without ETS, the menu on the display can be used.

Caution: In the case of parallel connection of channels, the device must only be commissioned using ETS. Commissioning without ETS may trigger an overcurrent or overtemperature alarm prematurely.

There are the following three functions available with different objectives, which should usually be used in this order:

1. Manual Operation (Set Brightness): Checking the wiring. Each channel can be switched individually.
2. Luminaire Calibration (Commissioning): Measuring the loads connected to the channels. All eight channels are calibrated simultaneously. The process takes approximately 5 minutes in total.
3. Test Mode (Manual Test): After calibration, the dimming behavior of the connected luminaires can be visually checked in the test mode. However, the parameters determined in this test mode cannot be saved directly to the device. It is therefore recommended to verify and apply them using ETS, as explained in the Interactive fine tuning section (p. 15).

Further information regarding these three functions is explained in the following sections. Commissioning with ETS is described in the section with this name.

## Menu Structure on the Device Display

The display on the device offers the following indicators and functions, which will be explained in more detail in the following sections.

#	Page Name	Label	Description
1	Power A–D		Current power in the channel in W / calibrated maximum power of the channel in W (For parallel-configured channels: total power / number of parallel channels)
2	Power E–F (Only for 8-channel variant)		Current power in the channel in W / calibrated maximum power of the channel in W (For parallel-configured channels: total power / number of parallel channels)
3	Alarms		Display of alarm states for all channels in a matrix
		Overcurrent	X: Overcurrent alarm triggered. Channel is turned off due to alarm. - : No overcurrent alarm. Channel is in normal state.
		Overtemperature	X: Overtemperature alarm triggered. Channel is turned off due to alarm. - : No overtemperature alarm. Channel is in normal state.
		Overvoltage	X: Overvoltage alarm triggered. Channel is turned off due to alarm. - : No overvoltage alarm. Channel is in normal state.
		Undervoltage	X: Undervoltage alarm triggered. Channel is turned off due to alarm. - : No undervoltage alarm. Channel is in normal state.
4	Set Brightness A–D		Manual operation for individual channels A–D in 10% steps
		Brightness A	Use SET to switch to the Brightness A submenu; the set value is immediately dimmed in the channel. <OK>: Brightness is retained and submenu exits. <CANCEL>: Channel is off and submenu exits.
		...	see above Brightness A
		<Exit>	Exits manual mode to display mode; retains the set brightness levels.
5	Set Brightness E–F (Only for 8-channel variant)		Manual operation for individual channels E–F in 10% steps (same behavior as A–D)
6	Commissioning		Commissioning functions for calibration and one-button setup
		Calibration	Shows if calibrated data is available for the channels: X: Data (Curve and max. Power) available and used when ETS parameter 'Calibrated control curve' or 'Calibrated load type' is selected. - : No calibrated data available. /: A rotating line indicates that the calibration process is currently running.

#	Page Name	Label	Description
		Process	Shows status of one-button commissioning: ready: Calibration can start. running: Calibration in progress.
		START commis- sioning	<All channels>: Starts calibration for all 8 channels (takes approx. 5 min). <Cancel>: Exits submenu.
		<Exit>	Exits commissioning mode; if process is running, cancels calibration.
7	Manual Test		Test mode for checking the dimming behavior of the channels
		Dim curve	Use SET to switch to dim curve submenu: <LIN>, <EXP>, <POT>, <ENERTEX> apply respective curves. <CANCEL>: No change.
		Start test A–D	Use SET submenu to start endless test sequence: <All channels>, <Only channel A>, <Only channel B>, <Only channel C>, <Only channel D>, <CANCEL>.
		Start test E–F (Only for 8-channel variant)	Same as Start test A–D for channels E–F.
		<Exit>	Ends test sequence, turns off all channels, switches to display mode.
8	Device Info		Displays device information parameters
		Ind. addr.	Physical KNX address.
		SN	Serial number.
		FW version	Firmware version
		CH version	Version of channels
		Time valid	Displays current time; shows INVALID if not set.
		Date valid	Displays current date; shows INVALID if not set.
9	FDSK	FDSK	Key for secure commissioning

Table 2: Menu structure Display UI

## Alarm functions

The device has four alarm functions: Overvoltage, undervoltage, overcurrent and overtemperature. These alarms serve to protect the device and cannot be parameterised. If an alarm occurs, the channel is switched off immediately. Sequences are also terminated immediately. Every active alarm is signalled via a corresponding alarm KO and shown on the device display.

An automatic restart function switches the channel back on to the brightness before the alarm. Automatic restart only takes place after an undervoltage alarm.

There is no automatic restart after the overcurrent overtemperature and overvoltage alarm. These alarms must be switched on manually via a switching OK or a dimming OK. The alarm KOs are active from the time they occur until the time they are successfully switched on again. They are automatically sent by the device when their value changes.

Once you have connected the devices, you can also use the alarm page to check them. For channels that have been wired, no undervoltage alarm (Alarm Undervoltage) must occur when the mains voltage is switched on in the distribution panel.

## Manual mode (Set Brightness)

Via the menu page "Set Brightness X-X", each channel can be individually controlled in increments of 10%. This control mode is intended for wiring tests during commissioning. If a channel selected in this mode is configured via ETS to be connected in parallel with another channel, all parallel channels will be dimmed to this same value. If channels have been wired in parallel but the device has not yet been correspondingly configured using ETS, this manual operation mode must not be used, as it may trigger an overcurrent or overtemperature alarm.

In manual mode, the dimming procedure parameterised in the ETS is used. The parameterised 'Dimming curve', 'Control curve' and the 'Calibration minimum control value' and 'Calibration maximum control value' parameters are also used.

If the device has not yet been programmed with the ETS, the device is in the as-delivered state (as after a factory reset) and the following standard parameters are used for dimming:

- Load type: 'Measured load type (leading or trailing edge phase control)'
- Light source control curve: 'Measured curve'
- Calibration of minimum control value: '0%'
- Calibration of maximum control value: '0%'
- Dimming curve: 'Enertex (D)'
- Parallel connection of channels: No (see 'Operating mode' parameter)

These parameters are always applied when the device is unloaded with the ETS. If the controlled channel has not yet been calibrated using the 'Start commissioning' function, the channel behaves as follows:

- Before dimming from 0% to 10%, the load type is automatically determined via a short one-off measurement of 2s and a corresponding dimming procedure is used. This prevents damage being caused to the dimmer if an unsuitable dimming behaviour is selected.

- The following default values are used for dimming:

- Light source control curve: 'Standard'
- Dimming curve: 'Enertex (D)'

Parallel connection of channels: No

If the channel has already been calibrated, the calibrated control curve and the calibrated minimum and maximum control value are used for each channel. The 'Commissioning' menu page provides information on which channels have already been calibrated.

## Calibrate the light source manually (commissioning)

The connected light sources can be calibrated via the 'Commissioning' menu page. This is done using the 'Start Commissioning' function. This starts the calibration process for all 8 channels simultaneously. This process takes approx. 2 minutes and measures the dimming curve of the light source in great detail based on the current consumption. See section 'Lamps' for further information on the calibration function. The lamps dim during this measurement. If the display switches to standby, you can wake up the display by pressing the DISPLAY button. During the calibration process, the display shows 'Calibration Process running'. After completion, 'ready' appears.

At the end, the 'Commissioning' menu page shows whether a channel has been successfully calibrated or not. Once the channels have been calibrated, the dimming behavior of the connected lamps can be checked visually on the 'Manual test' menu page.

## Manual test

### NOTE

**The parameters determined in this test mode cannot be saved directly on the device.**

Through the "Manual test" menu page, test sequences can be activated that dim the respective channels continuously from 0% to 100% and back from 100% to 0% within a 5-second cycle. This function is intended to test compatibility between lamps and dimmers and can be performed without ETS programming. If a selected channel has been configured via ETS to operate in parallel with another channel, all parallel channels will be tested simultaneously. If channels have been wired in parallel but have not yet been configured accordingly via ETS, this test operation must not be used, as it may trigger an overcurrent or overtemperature alarm.

The "Manual test" menu page can be used to activate test sequences that dim the corresponding channels in an endless loop from 0 to 100% and back from 100% to 0% in 5 seconds. This function is used to test the compatibility between the light source and dimmer and can be carried out without programming the ETS. However, parallel operation is ignored in test mode. For this reason, test mode must not be used with parallel-connected channels, as this can trigger an overcurrent or overtemperature alarm.

The following parameters are always used for dimming in test mode:

- Load type: “Measured load type (phase cut-on or phase cut-off)”
- Lamp control curve: “Measured curve”
- Parallel connection of channels: No

As the calibrated curves and values are used for dimming in this mode, the channels should be calibrated in accordance with the section “Calibrate the light source manually (commissioning)” before test operation. If no calibration has been carried out, the default values are used in accordance with the section Manual mode (Set Brightness).

In addition, the following settings that influence the dimming behavior can be varied for the test mode:

- “Dimming curve”: The value corresponds to the ETS parameter of the same name. The dimming curve can be changed here for testing and always applies to all channels in test mode. The dimming curves are explained in the “Dimming curves” section. This setting is volatile and is discarded when test mode is exited.

When the “Manual test” menu page is exited, all running test sequences are switched off and the dimming parameters set for the test are discarded. You can then enter the values found in the ETS parameters.

## Commissioning with ETS

This chapter provides background information on the various application scenarios and parameterization options for the Enertex® KNX HV Dimmer. Within the individual sections, there are often cross-references to the corresponding parameter descriptions, which in turn refer back to these explanations. This chapter provides background information on the various application scenarios and parameterization options for the Enertex® KNX HV Dimmer. Within the individual sections, there are often cross-references to the corresponding parameter descriptions. The parameter descriptions contain cross-references to the explanations.

## Dimming Curves

The dimmer offers four different dimming curves to choose from:

- Linear
- Exponential
- Power function
- Enertex

The human eye perceives brightness values logarithmically; that is, doubling the light intensity is not experienced as a doubling of brightness but as a much smaller increase. Although effects such as pupil dilation and the dark/light adaptation of rods and cones play a role, visual perception is often modeled logarithmically. At double the illumination, the 'perceived' brightness only increases by a factor of about 1.4. The Enertex curve provides the optimal response for users in many scenarios because it offers better resolution at lower brightness levels.

Using KNX-compliant percentage values, the dimmer adjusts brightness in 255 steps. These 255 control points (i.e., LED brightness levels) are distributed over the available dimming range by the Enertex® KNX HV Dimmer. The dimming curve can be set in the ETS application under General > Dimming Curve.

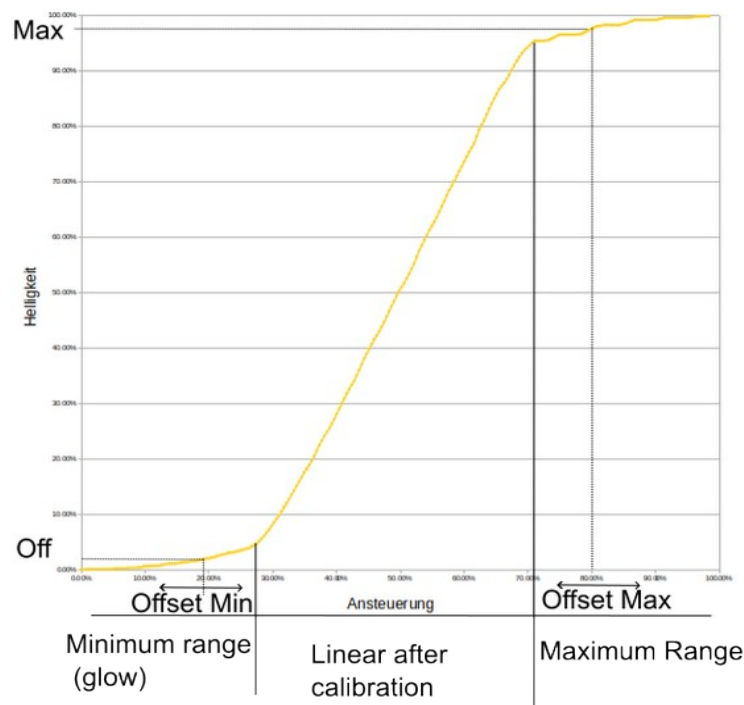

Figure 3: Characteristic of a lamp (schematic)

The brightness control must also account for the lamp's characteristic, which can vary significantly by type and series. LED lamps internally convert the phase cut-off or cut-on via electronics to a different control method. Therefore, in addition to the eye's logarithmic sensitivity, the

lamp's characteristic must be compensated to achieve smooth and pleasant dimming. Optionally, the dimmer measures the lamp's behavior via current consumption and compensates accordingly. The calibration process can be started via the display (see section "Calibrating the Lamps") or via communication objects (see section "Start Calibration of the Control Curve").

In Figure 3, you can see the 'Linear after Learning' region, which provides good correspondence between the set control level and the delivered brightness. In the lower minimal region, where the lamp barely 'glows,' fine-tuning the dimming curve for 'difficult' lamps is advantageous: learning based on current measurement only approximates brightness. The dimmer cannot measure actual luminosity. In the minimal region, brightness depends heavily on the lamp's electronics (and less on load current), so switching on may produce a less smooth jump from OFF to 1% brightness. As described below, this can be perfectly compensated by specifying or fine-tuning the minimum control value with an offset, enabling a gentle glow at very low control settings.

Similarly, the characteristic in the maximum region can be adjusted, especially when, as indicated in Figure 3, brightness between 90% and 100% control no longer noticeably increases. Here too, the user can specify an offset value.

## Light Sources

### Load Type

Depending on the load type, the appropriate control method can be used: phase cut-on for inductive loads and phase cut-off for capacitive loads.

The load type parameter can fix this setting. When set to 'Measured Load Type,' the connected load is determined once during commissioning (first program download). Additionally, setting 'Recalibrate on Undervoltage Alarm' forces load measurement after every mains failure.

Using the 'LED (Combination of Phase Cut-On/Off)' parameter, a special operating mode combining both methods can be selected. See the 'Standards Status' section for legal notes on this mode.

LED lamps often vary widely, even within the same model. Determining whether phase cut-off, cut-on, or the combined method is best may require experimentation.

### Control Curve

The control curve defines how the lamp is driven in phase cut-on/off mode for the smoothest and most linear dimming performance. The 'Standard' setting usually yields good results and is common in many dimmers. The 'Linear' setting is only recommended in exceptional cases.

Beyond direct selection, the Enertex dimmer can analyze the lamp's characteristic and calculate an optimized control curve (Light Source Correction Procedure, Low-Light Stabilization Procedure). To use this, set the parameter to 'Learned Control Curve' and perform the lamp measurement.

During learning, the entire control curve from 0% to 100% is measured and stored in the device until:

- The channel is released
- A factory reset occurs
- The channel's control method changes

From the measurement, the device calculates:

- Optimal control method for the connected lamps
- Optimal brightness control curve
- Minimum and maximum control values
- Maximum power of the connected lamp

This ensures uniform dimming up and down. For optimal behavior, relearn after each lamp change.

A learned curve depends on the lamp and load type. If either changes, relearn is required. Changing ETS parameters and downloading automatically triggers relearning.

The lamp must draw at least 500 mW at 100% brightness to learn the curve; otherwise, only 'Standard' and 'Linear' are available.

### Start Learning the Control Curve

For device firmware > 1.006, calibration of the control curve is automatically initiated after a program download or restart if the Control Curve parameter is set to "Calibrated Control Curve" and any dependent parameters have changed or the device is being commissioned for the first time.

Alternatively (or with firmware exactly 1.006) the calibration can be started either by operating the device itself or via a communication object on the KNX bus. This is particularly useful after replacing a light source.

Calibration of the control curve can be started without ETS or further knowledge by holding the "DISPLAY" button on the device for 10 s. The menu then switches to the Commissioning page and starts the calibration process for all eight channels. This process takes about 2 minutes and can therefore be carried out after the device has already been commissioned. The settings configured in ETS—such as the load type (i.e. dimming method) and any channels connected in parallel—are taken into account.

Using the KO Calibrate Channel the calibration process for load type and control curve can also be started via bus communication. Progress is reported via the KO Brightness Status. The process takes about 2 minutes, and several channels can be calibrated simultaneously.

The currently active dimming method and control curve for the channel can be queried via the KOs Active Dimming Method Feedback and Active Control Curve Feedback. A calibrated control curve is valid only for the determined dimming method of a specific light source and the selected parameters. On the device, open the "Commissioning" page and check the "Calibration" display—an "x" indicates that the curve for that channel has been learned.

When the calibration process is complete, a normal dimming operation can be started. If you notice, for example, that the light source switches on only at 10 %, this offset must be corrected (see section Adjusting the Min./Max. Control Value).

### Default Control Curve for the Lamp

If the parameter "Control Curve" is set to "Calibrated Control Curve" and the load type or dimming method is subsequently changed, the control curve becomes invalid. In this case, the standard control curve is used instead during dimming until a new calibration process is initiated.

### Adjustment of Min./Max. Control Values

An ETS parameter is provided for adjusting the minimum control value (Adjustment Value Min. Control Value) and another for adjusting the maximum control value (Adjustment Value Max. Control Value). The minimum and maximum control values define the brightness level that the light source should reach when 1% or 100% is specified. As described in the section Dimming Curves on page 11, this adjustment is primarily used to compensate for edge effects caused by the electronics built into the lamp. For fixed control curves, these two parameters define the dimming range limits of the light source. If a calibrated control curve is configured, these limits are determined by the implemented algorithm. Nevertheless, even in this case, the range limits can be manually adjusted using these two parameters. The minimum adjustment should be set so that the light source just starts to glow slightly at a dimming value of 1%. With certain calibrated LED light sources, it may happen that no glow is visible at 1% brightness. This can be corrected afterwards by adjusting the Adjustment Value Min. Control Value parameter, without needing to recalibrate the control curve. Thus, an additional offset can be specified for the minimum and maximum control values determined during the calibration process. Determining these two parameters can be done efficiently via interactive control of the device using the ETS (see next section).

## Interactive fine tuning

The interactive fine adjustment becomes fully functional only after the configured application has been transferred to the device at least once. Otherwise, the buttons mentioned below are grayed out.

Using the Test Adjust Min. button, the set value for Adjustment Value Min. Control Value is directly transferred to the device. This button is disabled if the device has not yet been initially programmed. Pressing the button loads the entered adjustment value into the dimmer, which then sets the light to the minimum dimming level of 1%. If the value for the minimum adjustment is too high, the light source will already shine too brightly when pressing the Test Adjust Min. button. In this case, the value should be reduced. Reducing the value may result in negative numbers for the Adjustment Value Min. Control Value parameter. If the lamp does not yet visibly light up, the value must be increased accordingly. The ideal value is typically determined iteratively but never requires a complete application download. It can be quickly changed by pressing the Test Adjust Min. button. The transferred Adjustment Value Min. Control Value is permanently stored in the device as if the application had been re-downloaded.

The maximum dimming value can be fine-tuned in the same way using the Test Adjust Max. button, which sets the dimmer to 100% (maximum brightness). The goal of this adjustment is to ensure that changes in brightness at the upper end of the dimming range still result in a perceptible change in light output.

With interactive fine adjustment, downloading the entire application can be avoided, which speeds up the commissioning process. However, during a regular download, all configured parameters will still be transferred to the device. If the interactive fine adjustment is completed, no program download is necessary, as the parameters are always stored correctly in the device's memory.

## Configuration Guidelines for Pleasant Dimming Behavior

1. If smooth ramp-up dimming is desired, the minimum control value should be set so that the lamp just begins to glow faintly at this level. Likewise, the maximum control value should be set at the point where no further increase in brightness is perceptible.
2. If the lamp flickers at low brightness levels, the dimming range limitation can be used. This limit should be set high enough that the lamp no longer flickers at that point. This not only ensures a smooth dimming process but also a flicker-free static brightness of the lamp.

## Switch-On Threshold Issue with Certain LED Lamps

Certain LED lamps only switch on once the brightness value exceeds a specific threshold. When already on, however, they can be dimmed to brightness values below this threshold. To switch on at brightness levels below that threshold, these lamps require a certain activation energy. The “Align Minimum Brightness for Switching On and Off” function supplies this activation energy when switching on. When the function is enabled, it is applied during every switch-on operation. The ideal activation-energy level depends on the lamp type and must be determined experimentally. Levels that are too high cause the lamp to flash briefly before switching on, whereas levels that are too low have virtually no effect.

Using the “Test Activation Energy” button, the parameters can be transferred directly to the device, and a dimming operation from 0 % to 1 % is started so that the modified parameters can be checked visually right away.

## Status of Standardization: Operating Mode LED Combination Leading-/Trailing-Edge

The LED operating mode (Combination of leading-edge/trailing-edge) uses both leading-edge and trailing-edge dimming. Because this mode produces increased radio-frequency interference emissions (9 kHz–30 MHz), only a lamp load of up to 100 W is permitted. In addition, the limits for the maximum allowable harmonic currents (100 Hz–2 kHz) for dimmers are defined in the EN IEC 61000-3-2 standard. That standard does not clearly address operation of dimmers in this combined mode. Although the harmonic distortion from the combined mode is lower than with purely leading-edge or purely trailing-edge dimming, this combined mode is not explicitly mentioned in the standard; therefore, within the EU it should not be used without additional filtering measures in the low-voltage network.

## Factory reset

The factory reset is performed by pressing and holding the PROG button for more than 10 seconds. During a factory reset, the device is returned to its original delivery state: all calibrated data for every channel are erased, the physical address is reset to 15.15.255, and the secure functions are deactivated so that the device can be used again without KNX Data Secure.

## Device description

### Display and control elements

The device provides the following display and control elements:

Button / LED	Function
PROG LED	Indicates KNX programming mode.
ALARM LED	Power supply indicator for active alarms (lights when any alarm is active).
POWER LED	KNX power supply indicator.
OLED display	Displays alarms, measurements, and commissioning parameters.
PROG button	KNX programming button; short press puts the device into programming mode. Press >10s resets the device to factory defaults.
DISPLAY button	Activates the display and navigates to the next page/entry. Press >10s initiates a new calibration process for all eight channels.
SET button	Selects the highlighted entry.

Table 3: Display and control elements

### Measurements and Counters

#### Measurements

The device measures, in each channel, current, voltage, power, and the temperature in that channel's power path. The current power readings are shown on the display. All measurement values are also made available via communication objects and can be sent cyclically and/or whenever they change on the bus. Using the current measurement, a luminaire protection can be configured to safeguard a lamp or its supply line from overload. See the section "Luminaire Protection." The measured power values also feed into the integrated energy counters.

#### Metering

For each channel, an energy meter, cost meter and operating-hours meter are available. This enables energy-consumption monitoring, cost control and tracking of the operating hours of luminaires. To calculate energy costs, you can either parameterize a fixed price per kWh in ETS or provide a price via the "Price" communication object. For further details, see the CO description in Table 4: Communication Objects.

Additionally, communication objects are provided to display the sum of the energy meters and cost meters across all channels.

### Luminaire protection

The luminaire protection serves to safeguard lamps and their supply lines. The device offers a configurable protection function that protects luminaires against thermal overload.

To activate and ensure correct operation of the luminaire protection, the following parameters must be specified: continuous (thermal) power, overload capacity (in %) and maximum overload duration.

Separate 1-bit alarm objects are provided for exceeding

- continuous power
- the  $I^2t$  value (for explanations, see chapter "Explanations on the  $I^2t$  shutdown")
- maximum power

Optionally, a shutdown linked to these three alarm objects can be enabled. If shutdown is activated, the channel's "Overcurrent Alarm" object also becomes active.

### Example configuration

- continuous power: 20 W
- overload capacity: 50 %
- maximum overload duration: 60 s

Triggers for the alarm objects and, if configured, the shutdown and “Overcurrent Alarm” object

- continuous power alarm object triggers when power exceeds 20 W
- maximum power alarm object triggers when power exceeds 30 W
- I<sup>2</sup>t alarm object triggers when power exceeds 20 W for more than 60 s or, according to equation 1, for example:
  - 25 W for more than 48 s
  - 35 W for more than 34 s
  - 100 W for more than 12 s

$$Time [s] = \frac{\text{continuous power} [W] \cdot \text{maximum overload duration} [s]}{\text{actual power} [W]}$$

Equation 1: Calculation of Overload Duration

### Explanations on the I<sup>2</sup>t shutdown

Luminaire and power-supply shutdowns can be configured to mimic the behavior of a fuse. They trigger a shutdown as soon as the rated current is exceeded by a certain amount for a sufficient duration. The higher the current, the faster the shutdown occurs. In terms of the device’s protection functions, this applies to power levels between the configured continuous power (below which no shutdown ever occurs) and the maximum power (above which shutdown occurs immediately).

Power levels in between (in figure 4 these are values between 100 W and 200 W) are shut down after a time that varies with the power level, from 500 s at 200 W up to 1000 s at 100 W.

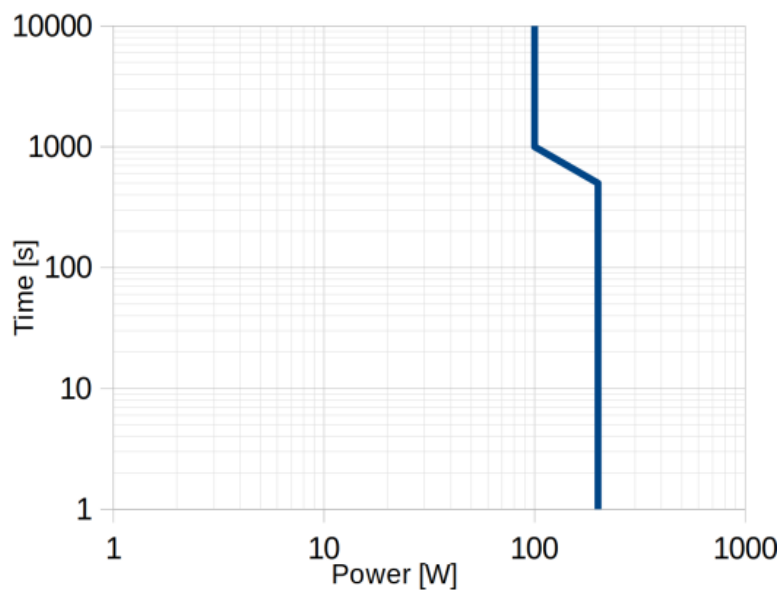

Figure 4: I<sup>2</sup>t shutdown

### Function of the time switch

## Description

Up to 16 time switches can be configured, each with an identical structure. For each of the 16 time switches a maximum of 4 so-called switching times can be parameterised. The parameterisation is carried out in the sub-menu called switching time 1 .. 4. There you can set a time and a telegram (or several) to be sent.

As the following figure shows, a telegram is sent on the bus when the switching time has occurred and the parameterised conditions for date or objects are fulfilled:

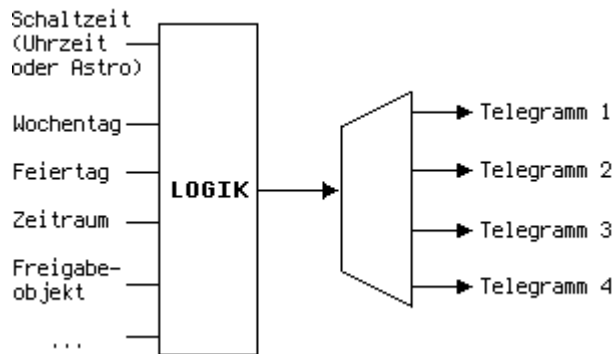

Figure 5: Diagram of the time switch

When a time switch is activated a telegram with the corresponding communication object is sent to the bus, e.g. "CO: Telegram 1". For the communication object, the type and the value to be sent must be pre-parameterised in the ETS. This is done under "Time switch - Configuration". During the configuration of these telegrams, certain entries are marked as "reserved." These entries are intended for future functionalities and should not be used.

The logic block shown in the figure is valid for the complete time switch, i.e. it is always the same for all 4 switching times of the time switch. It is configured under "Time-switch - Config". As inputs for the logic, special weekdays, public holidays, certain time periods or one of 3 global release objects from the bus can be used.

To use public holidays and periods, these must be defined before under "Define public holidays" or "Define periods".

## Lock objects

Each time switch also has its own lock object, with which the switching times of the time switch can be set to inactive. All switching times of the time switch are inactive as long as the lock object has the value ON. If the lock object is OFF or the lock object is not linked, the time switch is active.

## Example - Shutter control

The following example describes the often required application of a timer for a shutter control. Two shutter in the bedroom and in the kitchen, should be raised in the morning and lowered in the evening. Since the shutting down of the blinds in the evening should take place depending on the sunset, the astro function is used there. In addition, the blinds will be raised later in the morning on non-working days than on working days.

Two time switches are required for this functionality, as a distinction is made between working days and non-working days. For this reason, the number of time switches is set to 2 in the tab "Set time switches".

To drive the shutter, depending on the sunset, the astro function must be configured in the "Astro function" tab. There the location and the time zone must be defined.

As each time switch must trigger an action in the morning and in the evening, two switching times are required per time switch. The number of switching times is set in the tab "Time switch 1 - Config" and in the tab "Time switch 2 - Config".

A clearer structure of the parameterisation can be obtained by renaming the tabs appropriately. For this purpose the time switch 1 is renamed to "TimeSwWorkingDay" and time switch 2 to "TimeSwFreeDay". This is done via the input fields "Timer designation". Likewise, switching time 1 and switching time 2 are renamed to "Morning" and "Evening". This results in a very clear structure:

Designation for time switch	<input type="text" value="Multiple selection"/>
Number of switching times	<input type="text" value="2"/>
Configuration of possible telegrams	
Telegram 1	<input type="text" value="Shutter"/>
Operating mode	<input checked="" type="radio"/> Long term operation <input type="radio"/> Short time operation
Value specification	<input checked="" type="radio"/> On <input type="radio"/> From
Designation for CO	<input type="text" value="ShutterSleepUp"/>
Telegram 2	<input type="text" value="Shutter"/>
Operating mode	<input checked="" type="radio"/> Long term operation <input type="radio"/> Short time operation
Value specification	<input checked="" type="radio"/> On <input type="radio"/> From
Designation for CO	<input type="text" value="ShutterSleepDown"/>
Telegram 3	<input type="text" value="Shutter"/>
Operating mode	<input checked="" type="radio"/> Long term operation <input type="radio"/> Short time operation
Value specification	<input checked="" type="radio"/> On <input type="radio"/> From
Designation for CO	<input type="text" value="ShutterKitchenUp"/>
Telegram 4	<input type="text" value="Shutter"/>
Operating mode	<input checked="" type="radio"/> Long term operation <input type="radio"/> Short time operation
Value specification	<input checked="" type="radio"/> On <input type="radio"/> From
Designation for CO	<input type="text" value="ShutterKitchenDown"/>
Selection of days and/or conditions	

*Figure 6: Predefined telegrams for the time switches*

The next step is to configure the telegrams that should be sent at the switching times. Four different telegrams are required for the described application:

- Telegram 1 with value "Up" for the roller blind in the bedroom
- Telegram 2 with value "Down" for the roller blind in the bedroom
- Telegram 3 with value "Open" for the roller blind in the kitchen
- Telegram 4 with value "Down" for the roller blind in the kitchen

These four telegrams are configured in the "Time switch - Config" tab under "Configuration of possible telegrams". A data type and a value must be entered for each of the four telegrams. As can be seen in Fig. 6, the type long term blind operation is selected for all four telegrams. Telegrams 1 and 2 should be linked to the shutter in the bedroom, telegrams 3 and 4 to the shutter in the kitchen. Telegrams 1 and 3 are assigned the value "Up". This means that these communication objects are intended for raising the shutter. Telegrams 2 and 4 are used with the value "Down" to lower the shutter. The four communication objects can be named accordingly using the text fields "Designation for CO", which is used here for clarity. The communication object for telegram 1 is sensibly renamed "ShutterSleepUp". From this name, the function, location and value for the communication object can be seen immediately. Since the same telegrams are also required for time switch 2, these can be parameterised together by using the multiple selection with the control key in the ETS.

In the tab "1:Morning" the switching time in the morning can now be defined. In the example, a

fixed time for working days is selected here, whereby the shutter can also take over an wake up function:

Designation for the switching time	<input type="text" value="morning"/>
Designation for switching time change hour-CO	<input type="text"/>
Designation for switching time minute change-CO	<input type="text"/>
Switching time	
	<input type="text" value="Clock"/>
Hour	<input type="text" value="6"/>
Minute	<input type="text" value="30"/>
Second	<input type="text" value="0"/>
Selection of telegrams to be sent at the switching time	
The following preconfigured telegrams are sent at the switching time	<input type="text" value="1 &amp; 3"/>
<p><b>i</b> Here you can select which of the four telegrams are sent at the switching time. Under "Time switch - Config" the 4 possible telegrams can be defined with data type and value.</p>	

*Figure 7: Morning switching time*

In addition, the telegrams to be sent at this switching time must be selected here in the lower area. These would be telegrams 1 and 3, whose communication objects have previously been renamed "ShutterSleepUp" and "ShutterKitchenUp".

The second switching time called "2:evening" is parameterised depending on the sunset:

Designation for the switching time	<input type="text" value="evening"/>
Designation for switching time change hour-CO	<input type="text"/>
Designation for switching time minute change-CO	<input type="text"/>
Switching time	
	<input type="text" value="Astro - Sunset"/>
Offset for astro time (minutes)	<input type="text" value="30"/>
Selection of telegrams to be sent at the switching time	
The following preconfigured telegrams are sent at the switching time	<input type="text" value="2 &amp; 4"/>

*Figure 8: Evening switching time*

Due to the offset selected here, the two shutters are lowered 30 minutes after sunset. Here, too, the assignment to the pre-configured telegrams must be made. These would be telegrams 2 and 4 here, whose communication objects were previously renamed "ShutterSleepDown" and "ShutterKitchenDown".

The two switching times for time switch 2 are configured almost identically in the example. Thus, the multiple selection of the ETS could again be used for common parameterisation. In the example, however, the switching time "1:morning" for time switch 2, which is only to be active on non-working days, is subsequently changed to 9:30 a.m., so that the "Wake up function" on non-working days takes place later.

In addition, the days on which the respective time switch is active must also be specified. This is again done in the tab "TimeSwWorkingDay". The following figure shows these conditions:

Selection of days and/or conditions

Switching times active,

if  if not

Working day (without saturday) ▾

and never when ▾

Public holiday ▾

and never when ▾

Period 1 ▾

and never when ▾

Period 2 ▾

and never when ▾

Period 3 ▾

and never when ▾

Global release object 1 is ON ▾

**i** Example:  
 "Switching times active if period 1 or if period 2 and never if weekend" switches all 4 switching times on all working days in period 1 and period 2. Further examples are listed in the manual.

*Figure 9: Conditions for time switch 1: TimeSwWorkingDay*

According to the selected conditions, the two switching times of time switch 1 are active if a working day (Mo-Fr) but no public holiday (public holidays are defined later), no period 1 (is defined later as Easter holidays) is active, no period 2 (is defined later as Whitsun holidays), no period 3 (is defined later as Christmas holidays) and the "Global release object 1 ON" is not. The "Global Release Object 1" is a 1-bit object provided by the bus. The object could be used for example as a "holiday object" and set by a push button (possibly also by a button on the web server) at the beginning of a holiday and cleared at the end of a holiday. With this parameterisation the time switch is active on all days on which you go to work.

The time switch 2 is now parameterised to the contrary, so that it is only active on days when you have time off. This is done with this parameterisation:

Selection of days and/or conditions

Switching times active,

if  if not

Weekend ▾

or if ▾

Public holiday ▾

or if ▾

Period 1 ▾

or if ▾

Period 2 ▾

or if ▾

Period 3 ▾

or if ▾

Global release object 1 is ON ▾

**i** Example:  
 "Switching times active if period 1 or if period 2 and never if weekend" switches all 4 switching times on all working days in period 1 and period 2. Further examples are listed in the manual.

*Figure 10: Conditions for time switch 2: TimeSwFreeDay*

Finally, the used holidays and time periods still need to be defined. This is done in the tab "Define public holidays". In the example 5 holidays are defined, which are renamed again for clarity:

Name of the public holiday	Monday parish fair
	Day of the month
The	first
	Monday
at	August

*Figure 1112: Definition of public holidays*

The public holidays Easter Sunday, Ascension Day and Whit Sunday can be defined with the input option "Easter holiday". The exact date of the Easter holidays is calculated automatically by the unit for the respective year. As can be seen in fig. 11, the parish fair Monday is defined with the input option "day in month". Christmas Eve, on the other hand, is defined with the input option "Simple date". All these holidays can now be used as input for the conditions of the two time switches. This is also used in this example. Furthermore, the public holidays can also be used to define periods of time, such as holidays. This is shown in the next section.

In the tab "Define time periods", time periods can be defined which can be used for the conditions of the time switches. In the example 3 periods are defined: Easter holidays, Whitsun holidays, Christmas holidays:

Name of the time period	EasterHolidays
Name of the time period active-CO	EasterHolidayActive
First day of period	Depending on public holiday 1
Day after selected public holiday	-8
Duration of the period	
Number of days	14

*Figure 1314: Definition of periods*

As shown in Fig. 13, the Easter holidays are given in relation to Easter Sunday (= public holiday 1). According to the parameterisation the period starts 8 days before Easter Sunday, i.e. the Saturday one week before Easter at 00:00:00. With the duration of 14 days the period ends on the Friday after Easter at 23:59:59 hrs. Pentecost holidays are indicated in the same way. For the Christmas holidays you can also use a concrete date to enter the first day. For example, you can set the start day to 23.12. and define the duration of 15 days. This defines the Christmas holidays from 23.12. to 6.1.

The parameterisation of the example is now complete. Finally, in order to be able to send the telegrams of the two time switches on the bus, the eight predefined communication objects must be linked with the corresponding group addresses on the bus.

## ETS Application

### Specification

ETS: from version 5.7.4

### Database file

At <https://www.enertex.de/d-downloads.html> you will find the latest ETS database file and the current product description.

### Parameters

Any parameters that are not self-explanatory are integrated into the ETS context help.

### Communication objects

**Note: Depending on the configuration, some objects may not be available.**

ID	Function	Object function	Description	Length	DptType
ID	Function	Object Function	Description	Length	DPT Type
1	Time – Input	Date	Sets the date of the internal real-time clock. Required for time-controlled dimming functions and automatic day/night switching.	3 Bytes	DPST-11-1
2	Time – Input	Time	Sets the time of the internal real-time clock. Required for time-controlled dimming functions and astro function (sunrise/sunset calculation). If no valid time is provided, time-controlled dimming will never activate.	3 Bytes	DPST-10-1
3	Time – Input	Date / Time	Sets both date and time of the internal real-time clock (combined object).	8 Bytes	DPST-19-1
4	Time – Input	Day (0) / Night (1)	Sets the device to day or night mode. Different switch-on brightness levels can be parameterized accordingly.	1 Bit	DPST-1-24
6	Measurement – Output	Power Consumption	Returns the currently measured total active power across all 8 or 4 channels, respectively. Always the sum of all channel-dependent power values.	4 Bytes	DPST-14-56
10	Counter – Input	Electricity Price (0.1 ct/kWh)	Sets the electricity price for cost counter calculations.	2 Bytes	DPST-7-1
11	Counter – Output	Lifetime Energy Consumed	Returns the total energy consumed from the grid across all 8 or 4 channels, respectively, over the device's lifetime. Cannot be reset.	4 Bytes	DPST-13-10
12	Counter – Output	Lifetime Energy Cost	Returns the total energy cost (in 0.1 ct) of energy consumed across all 8 or 4 channels, respectively, over the device's lifetime. Cannot be reset.	4 Bytes	DPST-13-1
13	Counter – Output	Lifetime Operating Hours	Returns the device's operating hours in seconds over its lifetime. Counts while the device is on the bus, regardless of channel state. Cannot be reset.	4 Bytes	DPST-13-100
14	Counter – Output	Energy Consumed	Analogous to 'Lifetime Energy Consumed', but can be reset to 0 via the 'Reset' object. Not reset on device restart or reprogramming.	4 Bytes	DPST-13-10
15	Counter – Output	Energy Cost	Analogous to 'Lifetime Energy Cost', but can be reset to 0 via the 'Reset' object. Not reset on device restart or reprogramming.	4 Bytes	DPST-13-1
16	Counter – Output	Operating Hours	Analogous to 'Lifetime Operating Hours', but can be reset to 0 via the 'Reset' object.	4 Bytes	DPST-13-100
17	Counter – Input	Reset	Resets the energy, cost, and operating hours counters to 0. Lifetime counters remain unaffected.	1 Bit	DPST-1-17

21		Central Function 1 – Switching	Switches all individual channels for which the parameter has been activated.	1 Bit	DPST-1-1
22		Central Function 1 – Relative Dimming	Absolute dimming of all individual channels for which the parameter has been activated.	4 Bit	DPST-3-7
23		Central Function 1 – Absolute Dimming	Relative dimming of all individual channels for which the parameter has been activated.	1 Byte	DPST-5-1
		Central Function 2 ... 8	Communication objects for central functions 2 to 8. Refer to central function 1 for descriptions.		
45	A (...) - Input	Switch	Channel switch. Behavior (switch-on behavior, speed, etc.) depends on parameterization. Dimming speed defined by 'switch-on speed' and 'switch-off speed'. Triggers staircase lighting if enabled.	1 Bit	DPST-1-1
46	A (...) - Output	On/Off Status	On/Off status of the dimming actuator.	1 Bit	DPST-1-1
47	A (...) - Input	Relative Dimming	Relatively dims the channel. Dimming speed defined by 'Relative Dimming Speed'. Cannot switch on if 'Switch on when dimming' is set to 'No'. Cannot switch off if min limit >0%.	4 Bit	DPST-3-7
48	A (...) - Input	Absolute Dimming	Dims the channel to an absolute percentage value. Dimming speed defined by 'Absolute Dimming Speed'.	1 Byte	DPST-5-1
49	A (...) - Output	Brightness Status	Feedback of channel brightness in percent. During calibration, indicates progress of the calibration process.	1 Byte	DPST-5-1
50	A (...) - Input	Recalibrate	Starts/stops the calibration process (~2 min). Cannot be interrupted except by sending a stop command to this object.	1 Bit	DPST-1-10
51	A (...) - Output	Active Dimming Method Feedback	Indicates currently applied dimming method: leading edge or trailing edge.	1 Byte	DPST-20-609
52	A (...) - Output	Active Control Curve Feedback	Indicates currently applied control curve in text: 'linear', 'standard', or 'calibrated'.	14 Bytes	DPST-16-1
53	A (...) - Input	Switch-on brightness	Object for Adjusting the Switch-On Brightness	1 Byte	DPST-5-1
54	A (...) - Output	Power Measurement	Returns the currently measured active power in the channel.	4 Bytes	DPST-14-56
55	A (...) - Output	Current Measurement	Returns the currently measured channel current as an RMS value.	4 Bytes	DPST-14-19
56	A (...) - Output	Voltage Measurement	Returns the currently measured channel voltage as an RMS value.	4 Bytes	DPST-14-27
57	A (...) - Output	Learned Maximum Power	Returns the maximum active power measured in the channel. The value corresponds to the Max. Power value shown on the display.	4 Bytes	DPST-14-27
59	A (...) - Output	Total Energy Consumed Counter	Analogous to 'Lifetime Energy Consumed', but for the channel only. Cannot be reset.	4 Bytes	DPST-13-10
60	A (...) - Output	Total Energy Cost Counter	Analogous to 'Lifetime Energy Cost', but for the channel only. Cannot be reset.	4 Bytes	DPST-13-1
61	A (...) - Output	Total Operating Hours Counter	Returns operating hours in seconds when channel is ON. Cannot be reset.	4 Bytes	DPST-13-100
62	A (...) - Output	Energy Consumed Counter	Analogous to 'Total Energy Consumed', but can be reset via 'Reset' object.	4 Bytes	DPST-13-10
63	A (...) - Output	Energy Cost Counter	Analogous to 'Total Energy Cost', but can be reset via 'Reset' object.	4 Bytes	DPST-13-1
64	A (...) - Output	Operating Hours Counter	Analogous to 'Total Operating Hours', but can be reset via 'Reset' object. Suitable for planned maintenance to record lamp lifetime.	4 Bytes	DPST-13-100
65	A (...) - Input	Reset Counter	Resets the channel's energy, cost, and operating hours counters to 0. Total lifetime counters unaffected.	1 Bit	DPST-1-17
66	A (...) -	Wake-up light	Trigger for the comfort function Wake-up light	1 Bit	DPST-1-17

	Input				
67	A (...) - Input	Falling-asleep light	Trigger for the comfort function Falling-asleep light	1 Bit	DPST-1-17
69	A (...) - Input	Scene	Activates the channel scene or saves the current brightness value for the scene if enabled.	1 Byte	DPST-18-1
70	A (...) - Input	Bit Scene 1	Activates/deactivates bit scene 1 of the channel.	1 Bit	DPST-1-1
		Bit Scene 2 ... 8	Communication objects for bit scenes 2 to 8. Refer to Bit Scene 1 for descriptions.		
78	A (...) - Input	Time-Controlled Dimming Start/ Stop	Sequence to start/stop time-controlled dimming. While active, brightness values are updated according to the configured time series at 1s intervals with continuous transitions.	1 Bit	DPST-1-10
79	A (...) - Output	Time-Controlled Dimming Status Start/Stop	Status of the time-controlled dimming sequence (Start/ Stop).	1 Bit	DPST-1-10
80	A (...) - Input	Lock Function 1	Activates/deactivates lock function 1 of the channel.	1 Bit	DPST-1-1
81	A (...) - Input	Lock Function 2	Activates/deactivates lock function 2 of the channel.	1 Bit	DPST-1-1
82	A (...) - Input	Lock Status	Feedback indicating whether either lock function (1 or 2) is active.	1 Bit	DPST-1-1
83	A (...) - Output	Overvoltage Alarm	Returns alarm (1) when the measured mains voltage exceeds 260VAC. When an alarm occurs, the alarm object is set and automatically sent. The channel is immediately switched off, and any running sequences are terminated as well. To switch back on, a switching command must be sent either from the bus or via the display. The alarm state in the object is only cleared after a successful reactivation.	1 Bit	DPST-1-5
84	A (...) - Output	Undervoltage Alarm	Returns alarm (1) when the measured mains voltage drops below 80 VAC. When an alarm occurs, the alarm object is set and automatically sent. The channel is immediately switched off, and any running sequences are also terminated. In the event of a power failure, the device features an automatic restart function that restores the channel to its last brightness level once the mains voltage returns. After successful reactivation, the alarm state in the object is cleared.	1 Bit	DPST-1-5
85	A (...) - Output	Overcurrent Alarm	Returns alarm (1) when a current threshold critical to the device is reached. The alarm may have several causes: 1. In the case of a short circuit in the load, the channel is switched off immediately and an alarm is triggered. This disconnection occurs significantly faster than a 10 A or 16 A circuit breaker upstream in the distribution board. This function is designed not to trigger when charging large capacitors in the load. 2. When an impermissibly high rated load is connected to the channel. In this case, the alarm is triggered with a delay if 1.5 Arms (= 50 % overload of the channel) flows for at least 1 s. 3. This alarm object can also be triggered by the configurable lamp protection. The parameter "Enable Protection Shutdown" determines whether this alarm object is triggered. When this alarm occurs, the alarm object is set and automatically sent. The channel is immediately switched off, and any running sequences are terminated as well. To switch back on, a switching command must be sent from the bus or via the display. The alarm state in the object is only cleared after a successful reactivation.	1 Bit	DPST-1-5
86	A (...) - Output	Overtemperature Alarm	Returns alarm (1) when the measured temperature in the power path of the channel exceeds 100 °C. When an alarm occurs, the alarm object is set and automatically	1 Bit	DPST-1-5



			sent. The channel is immediately switched off, and any running sequences are also terminated. In the event of an impermissible overload of the channel, this protection is triggered to prevent the device from overheating. To switch back on, a switching command must be sent from the bus or via the display. The alarm state in the object is only cleared after a successful reactivation. transmitted. The channel is immediately switched off, and any running sequences are stopped. In the event of an impermissible overload of the channel, this protection mechanism is triggered to prevent the device from overheating. To switch the channel back on, a switching command must be issued via the bus or the display. The alarm state in the object is only cleared after a successful restart.		
87	A (...) - Output	Load Deviation Warning	Returns an alarm (1) when the power value of the lamp/channel deviates by more than 10% from the calibrated power value. This may indicate a lamp failure in the channel and can serve as a hint to replace the lamp. Alternatively, the warning can be triggered by a lamp replacement without recalibration, especially if the new lamp differs from the previous one. The channel is not switched off when the warning is triggered. The warning is only cleared when the channel's power is again within $\pm 10\%$ of the calibrated value or after a new calibration has been performed.	1 Bit	DPST-1-5
88	A (...) - Output	Continuous Power Protection Exceeded	Returns alarm (1) when the configured continuous power threshold for lamp protection is exceeded for channel B. Requires 'Lamp protection active' parameter.	1 Bit	DPST-1-5
89	A (...) - Output	Lamp Protection Maximum Power Exceeded	Returns alarm (1) when maximum power (continuous + overload capacity) is exceeded. Channel off only if configured in protection parameters.	1 Bit	DPST-1-5
90	A (...) - Output	Power Supply Protection Maximum Power Exceeded	Returns alarm (1) when the configured maximum power for power supply protection is exceeded.	1 Bit	DPST-1-11
		Kanal 2 ... 8	Kommunikationsobjekte für die Kanäle 2 bis 8. Für die Beschreibung sei auf die Objekte von Kanal 1 verweisen.		
445	Logic 1 (...)	Logic Gate Input 1	1-bit object as input 1 of a logic gate (1...8). The input state can optionally be inverted. Available only when logic function type is 'Logic Gate' and input 1 is used.	1 Bit	DPST-1-2
		Converter Lock Function	1-bit object as input of a converter. Configurable to respond to ON and OFF commands or only one type. Available only when logic function type is 'Converter'.	1 Bit	DPST-1-2
		Locking Element Function	1-bit object as input of a locking element. Available only when logic function type is 'Locking Element'.	1 Bit	DPST-1-2
		Comparator Input	4-byte object as input of a comparator. Available only when logic function type is 'Comparator' and data format is '4 Byte Value -2147483648...2147483647 (DPT 13.001)'.	4 Bytes	DPST-13-1
		Threshold Switch Input	4-byte object as input of a threshold switch. Available only when logic function type is 'Threshold Switch' and data format is '4 Byte Value -2147483648...2147483647 (DPT 13.001)'.	4 Bytes	DPST-13-1
446	Logic 1 (...)	Logic Gate Input 2	1-bit object as input 2 of a logic gate (1...8). The input state can optionally be inverted. Available only when logic function type is 'Logic Gate' and input 2 is used.	1 Bit	DPST-1-2
		Converter Input	1-bit object as converter lock input. A locked converter holds last value and ignores further inputs. Telegram polarity is configurable. Available only when logic function type is 'Converter'.	1 Bit	DPST-1-2
		Locking Element Input	1-bit object as lock element input. A locked element holds last output and ignores inputs. Telegram polarity is configurable. Available only when logic function type is	1 Bit	DPST-1-2

			'Locking Element'.		
447	Logic 1 (...)	Logic Gate Input 3	1-bit object as input 3 of a logic gate (1...8). The input state can optionally be inverted. Available only when logic function type is 'Logic Gate' and input 3 is used.	1 Bit	DPST-1-2
448	Logic 1 (...)	Logic Gate Input 4	1-bit object as input 4 of a logic gate (1...8). The input state can optionally be inverted. Available only when logic function type is 'Logic Gate' and input 4 is used.	1 Bit	DPST-1-2
449	Logic 1 (...)	Logic Gate Output	1-bit object as output of a logic gate (1...8). Available only when logic function type is 'Logic Gate'.	1 Bit	DPST-1-2
		Converter Output	1-byte object as value output of a converter. Available only when logic function type is 'Converter'.	1 Byte	DPST-5-1
		Locking Element Output	1-bit object as output of a locking element. Available only when logic function type is 'Locking Element'.	1 Bit	DPST-1-2
		Comparator Output	1-bit object as output of a comparator. Fixed to 1-Bit (DPT 1.002). Indicates result of comparison (ON=true/OFF=false). Available only when logic function type is 'Comparator'.	1 Bit	DPST-1-2
		Threshold Switch Output	1-bit object as output of a threshold switch. Fixed to 1-Bit (DPT 1.002). Indicates evaluation result (ON=true/OFF=false). Available only when logic function type is 'Threshold Switch'.	1 Bit	DPST-1-2
	Logic 2 ... 8		Communication objects for logic gates 2 to 8. Refer to objects of logic gate 1 for descriptions.		
654	Holiday	Holiday	Communication object indicates whether the current day is a configured holiday (ON=1, OFF=0). Day runs from 00:00:00 to 23:59:59. Can send on change if configured.	1 Bit	DPST-1-2
644	Period 1	Period 1	Communication object has value 1 when the current day is in configured period 1, otherwise 0. Can send on change if configured.	1 Bit	DPST-1-2
	Period 2 ... 10		Communication objects for time periods 2 to 10. Refer to period 1 for descriptions.		
491	Global Release Object 1	Global Release Object 1	Communication object that can be set via the bus and used as input for timer logic conditions.	1 Bit	DPST-1-2
492	Global Release Object 2	Global Release Object 2	Communication object that can be set via the bus and used as input for timer logic conditions.	1 Bit	DPST-1-2
493	Global Release Object 3	Global Release Object 3	Communication object that can be set via the bus and used as input for timer logic conditions.	1 Bit	DPST-1-2
500	Timer 1 Lock Object	Timer 1 Lock Object	Lock object for timer 1, which can be set via the bus. When ON, all schedules of timer 1 are inactive; when OFF or not linked, schedules are active.	1 Bit	DPST-1-2
501	Timer 1 - Switching Time 1: HH	Timer 1 - Switching Time 1: HH	Changes the hour of timer 1 switch time 1 (unit: hours). If written via bus, this value overrides ETS parameter until restart. Ignored if configured to sunrise/sunset.	1 Byte	DPST-5-10
502	Timer 1 - Switching Time 1: MM	Timer 1 - Switching Time 1: MM	Changes the minute of timer 1 switch time 1 (unit: minutes). If written via bus, this value overrides ETS parameter until restart. Ignored if configured to sunrise/sunset.	1 Byte	DPST-5-10
503	Timer 1 - Switching Time 2: HH	Timer 1 - Switching Time 2: HH	Changes the hour of timer 1 switch time 2 (unit: hours). If written via bus, this value overrides ETS parameter until restart. Ignored if configured to sunrise/sunset.	1 Byte	DPST-5-10
504	Timer 1 - Switching Time 2: MM	Timer 1 - Switching Time 2: MM	Changes the minute of timer 1 switch time 2 (unit: minutes). If written via bus, this value overrides ETS parameter until restart. Ignored if configured to sunrise/sunset.	1 Byte	DPST-5-10
505	Timer 1 - Telegram 1	Timer 1 - Telegram 1	Communication object that can be sent by timer 1 when the corresponding switch time occurs and timer logic conditions are met. Type and value depend on 'Possible Telegram Configuration' parameter.	3 Bytes	DPST-232-600
506	Timer 1 -	Timer 1 - Tele-	Communication object that can be sent by timer 1 when	3 Bytes	DPST-232-

	Telegram 2	gram 2	the corresponding switch time occurs and timer logic conditions are met. Type and value depend on 'Possible Telegram Configuration' parameter.		600
507	Timer 1 - Telegram 3	Timer 1 - Telegram 3	Communication object that can be sent by timer 1 when the corresponding switch time occurs and timer logic conditions are met. Type and value depend on 'Possible Telegram Configuration' parameter.	3 Bytes	DPST-232-600
508	Timer 1 - Telegram 4	Timer 1 - Telegram 4	Communication object that can be sent by timer 1 when the corresponding switch time occurs and timer logic conditions are met. Type and value depend on 'Possible Telegram Configuration' parameter.	3 Bytes	DPST-232-600
	Timer 2 ... 16		Communication objects for timers 2 to 16. Refer to objects of timer 1 for descriptions.		
445	Logic 1 (...)	Logic Gate Input 1	1-bit object as input 1 of a logic gate (1..8). The input state can optionally be inverted. Available only when logic function type is 'Logic Gate' and input 1 is used.	1 Bit	DPST-1-2
		Converter Lock Function	1-bit object as input of a converter. Configurable to respond to ON and OFF commands or only one type. Available only when logic function type is 'Converter'.	1 Bit	DPST-1-2

*Table 4: Communication Objects*

## Device Specifications

Inputs	<p>Power Supply:</p> <p>Rated voltage: AC 230–240 VAC</p> <p>Mains frequency: 50 Hz (+-10%)</p> <p>Standby power: &lt; 0.2 W per channel</p> <p>Nominal current: 1.1 A per channel</p> <p>Mains input protection: max. 16 A (Type B)</p> <p>KNX Supply:</p> <p>Voltage: 21 ... 32 V DC</p> <p>Current consumption of 8 channel variant: &lt; 70 mA (typ. 55mA)</p> <p>Current consumption of 4 channel variant: &lt; 45 mA (typ. 37mA)</p>
Outputs	<p>8 (at 8 channel varian) or 4 (at 4 channel variant) phase cut-on or cut-off dimmed outputs for various luminaires:</p> <p>- Incandescent/HV halogen lamps: 250 W</p> <p>- HV LED lamps (trailing edge): 200 W</p> <p>- HV LED lamps (leading edge): 100 W</p> <p>- Electronic transformer (trailing edge): 200 W</p> <p>- Wound transformers (leading edge): 200 W</p>
Protection Functions	<p>Overcurrent cutoff: manual reset required</p> <p>Overvoltage cutoff: manual reset required</p> <p>Undervoltage cutoff: automatic restart when voltage returns</p> <p>Overtemperature cutoff: automatic restart after cooldown</p> <p>Alarm LED and states: Alarm LED turns off when all alarms cleared; alarm cleared upon successful channel reactivation</p>
Controls and Indicators	<p>OLED display</p> <p>LEDs: PROG, ALARM, POWER</p> <p>Buttons: PROG, DISPLAY, SET</p>
Connections	<p>AC Power :</p> <p>Connector type: screw terminal, torque: 0.5 Nm</p> <p>Conductor cross-section rigid: 0.5 – 4.0 mm<sup>2</sup></p> <p>Conductor cross-section flexible without ferrule: 0.5 – 4.0 mm<sup>2</sup></p> <p>Conductor cross-section flexible with ferrule: 0.5 – 2.5 mm<sup>2</sup></p> <p>2 conductors of the same cross-section rigid: 0.2 – 1.5 mm<sup>2</sup></p> <p>2 conductors of the same cross-section flexible: 0.2 – 1.5 mm<sup>2</sup></p> <p>2 conductors of the same cross-section flexible with TWIN ferrule with plastic sleeve: 0.5 – 1.5 mm<sup>2</sup></p> <p>KNX Connection</p> <p>Connector type: black/red terminal (Type 5.1)</p> <p>Conductor diameter: 0.8 mm solid</p>
Enclosure	<p>DIN rail enclosure for 35 mm rail</p> <p>8 channel variant:</p> <p>Width: 6 MW</p> <p>Dimensions: 106 × 89.6 × 62.9 mm (L × W × H)</p> <p>4 channel variant:</p> <p>Width: 4 MW</p> <p>Dimensions: 71.5 x 89.6 x 62.9 mm (L × W × H)</p>
Additional	<p> Indoor use only</p> <p> Electronic control gear with double insulation, Protection class II</p> <p>Panel mounting only</p> <p>Max. ambient temperature: 45 °C</p> <p>Min. ambient temperature: -5 °C</p> <p>Protection rating: IP20</p> <p>Approvals:</p> <p>Communication: KNX certified</p> <p>Safety: EN 61347-2-13, IEC 63044-3</p> <p>EMC: IEC 63044-5-2 (residential), IEC 63044-5-3 (industrial)</p> <p>Environment: EN 50491-2</p>